



Contents

Introduction	
General	2
Receiving	2
Specifications	
General	2
At 20°C	2
Mechanical	2
Installation	
Mechanical	
Mounting	3
Temperature Environment	3
Moist or Corrosive Atmospheres	3
Hazardous Locations	3
Electrical	
Power Supply	4
Wiring	4
Transients	4
Configuration Menu	
General	4
Guide	5
Menu	6
Maintenance	6
Repair and Warranty Service	6

Illustrations

Figures	
Indicator Dimensions (fig.1)	3
Burns Connection Head Dimensions	
#19 (fig.2)	3
#20 (fig.3)	3
Connection Schematic(fig.4)	4
Wiring Schematic (fig.5)	4
Switch Location (fig.6)	5
Enter and Escape Schematic (fig.7)	5
User-defined Linearization (fig.8)	6
menu Schematic (fig.9)	6



While this information is presented in good faith and is believed to be accurate, Burns Engineering cannot guarantee satisfactory results from reliance upon this information.

For complete warranty information, please request a copy of Burns Engineering form #0475143 "Terms and Conditions of Sale"

Burns Connection Head Models #19 & #20 with Loop Powered LED Indicator Instruction Manual

Introduction

-General

Both the Burns #19 and #20 connection heads use the same loop powered process indicator with a 4-digit red LED display. The indicator accepts a 4-20mA input signal and displays the associated process variable.

The instrument configuration settings are selectable via a simple to use menu system, which is navigated by the use of three push bottom keys located on the rear of the indicator display.

The indicator can be driven by the Burns Model T51 or T55 transmitters which sit in the same head underneath the indicator making a compact efficient package; or it can be run from any 4 to 20 mA source and display the desired process variable.

The indicator assembly is sealed into a cap that fits directly onto Burns #19 and #20 connection heads.

Other features include:

- Two wire current loop indicator
- Powered by a 4-20 mA DC process signal
- Screw terminal connections on the indicator
- Three push button programmable menu
- Password protection
- Contains several linearizations which can be applied to display square root, $x^{3/2}$, $x^{5/2}$ or a user defined 19 segment linearization curve.
- NEMA 4X (Burns Connection Head Model #20)
- FM approval (Burns Connection Head Model #19)

-Receiving

Please inspect the packaging and instrument thoroughly for any signs of transit damage. If the part has been damaged, please notify your supplier immediately.

Specifications

-General

- Display: 4 digit LED 7.6mm red LED
- Decimal Point: Programmable
- Range: -1999 to 9999
- Linearization: Linear, Square root, Power $3/2$, Power $5/2$, user
- User Characteristics: Up to 20 pairs by straight line interpolation
- Hart Transparent: Yes
- Power: Loop powered
- Loop Drop: Less than 4 V @ 20mA
- EMC Emissions: BS EN61326
- EMC Immunity: BS EN61326

-At 20°C

- Input: 4 to 20 mA
- Max Input Current: 100 mA for 1 minute
- Accuracy: $\pm 0.02\%$ of full scale input
- Stability Zero: $\pm 0.002\%/^{\circ}\text{C}$
- Stability Span: $\pm 0.01\%/^{\circ}\text{C}$
- Ambient Temperature: -20° to 75°C
- Ambient Storage: -50° to 85°C
- Ambient Humidity: 10 to 90% RH

-Mechanical

- Connection: Two way screw terminal block
- Maximum Wire Size: 16 AWG max. (0.054" dia.)
- Environmental Rating: IP67
- Material (Burns#19): Aluminum, blue polyester powder coating
- Material (Burns #20): Polycarbonate

(Burns #20): Polycarbonate

- Approval (Burns#19): FM explosion proof
- Approval (Burns #20): NEMA 4X

Figure 1
Indicator Dimensions

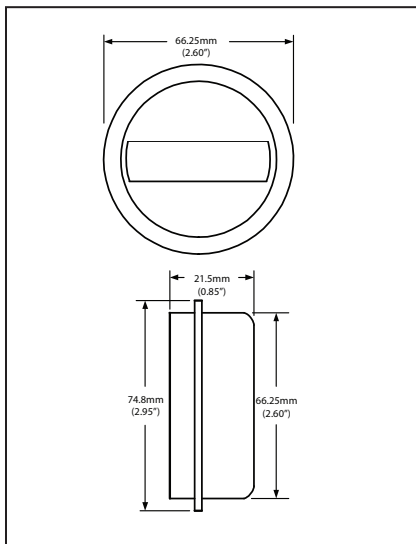

Figure 2
Burns Connection Head #19 Dimensions

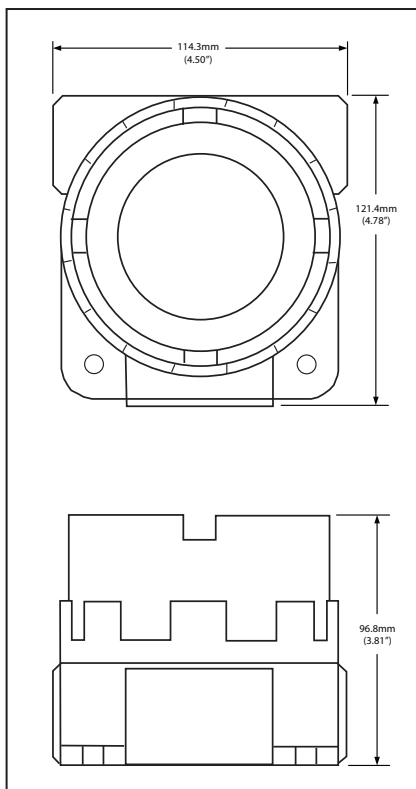
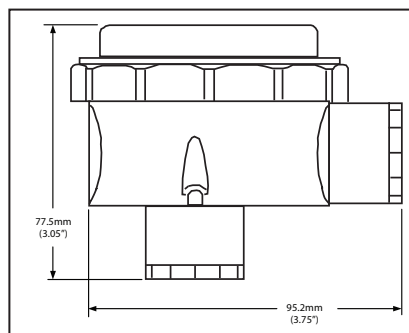

Figure 3
Burns Connection Head #20
Dimensions



Installation Mechanical

-Mounting

The entire indicator assembly is sealed in the cap that fits directly into the Burns #19 Explosion proof and #20 NEMA 4X connection heads. The connection heads have provisions for including temperature transmitters. Optional kits are available for pipe mount and DIN rail mounting.

-Temperature Environment

The indicator assembly will operate within specifications for ambient temperatures in the range of -20°C to 75°C (-4°F to 167°F). It can be stored without damage at temperatures in the range of -50°C to 85°C (-58°F to 185°F).

-Moist or Corrosive Atmospheres

The Burns Connection Head Model #20 has been designed to resist moisture and corrosive environments. However, during prolonged exposure, corrosion of the screws can occur. Significant corrosion to the screws can increase the contact resistance between the PRT/ power supply leads and the terminal block, causing erroneous readings and/or complete lack of output. Replacing and/or cleaning the screws will usually remedy the problem.

-Hazardous Locations

The Burns Connection Head Model #19 is FMRC approved as an intrinsically safe device when used

with properly selected FMRC approved assemblies.

Installation Electrical

-Power Supply

The maximum current rating for this device is 100mA for 1 minute. Exceeding this value will destroy this device. Fuse protection of the current loop to which this device is connected is highly recommended.

This unit must only be series connected to a 4 to 20mA current loop. This device will be destroyed if connected directly across any supply with a current output greater than 100mA.

Ensure the instrument is installed with adequate protection against the environment. IP67 must be maintained.

Avoid installing the equipment close to sources of extreme temperature and electrical or electromagnetic interference.

-Wiring

Connect the device to a 4 to 20mA loop, set at any value between 4 and 20mA. All external cabling/sensor entries must maintain IP67 rating.

Figure 4
Connection Schematic

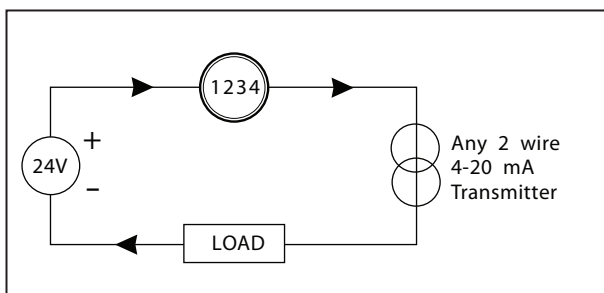
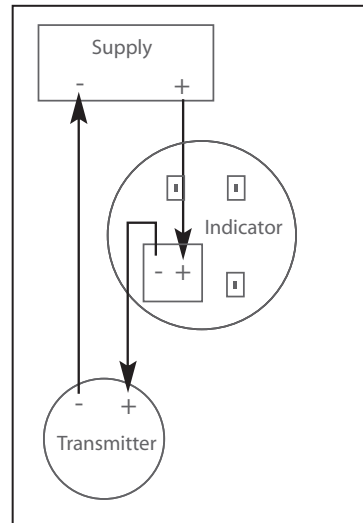

Figure 5
Wiring Schematic



-Transients

High-energy transients can damage assemblies with transmitters. If the assembly is to be installed in an area where high-energy transients are probable, the input circuitry should be fitted with appropriate transient suppression circuitry. Consult factory for details.

Configuration Menu

-General

There are three buttons, which the operator must press in various combinations in order to configure the device. These buttons are located on the underside of the indicators circuit board. Viewed from the front the three buttons, cycle (CYC), Increment (INC) and Decrement (DEC) are shown in black, figure 6. Pressing two buttons simultaneously causes enter (ENT) or escape (ESC) actions, figure 7. If no buttons are pressed for a minute or more, the device assumes run-time mode. The display shows the Process variable (PV) if the input is in range or shows - - - - or - - - - to indicate over/under range. In order to access menu configuration mode, the user must press enter (figure 7) followed immediately by cycle (figure 6). In order to exit the menu and return to run-time, a user must press escape (figure 7).

Figure 6
Switch Location

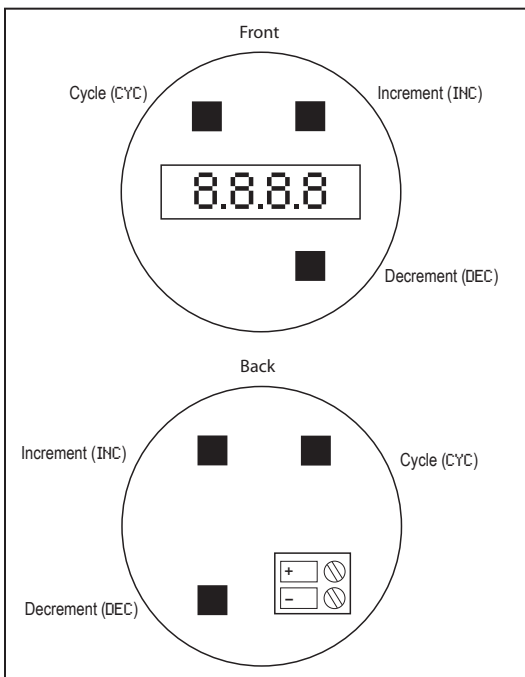
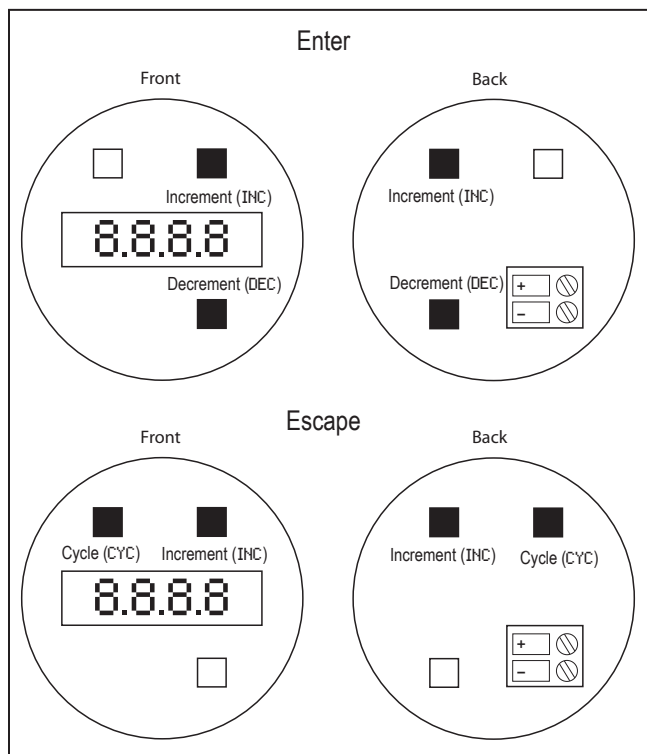

Figure 7
Enter and Escape Schematic



-Guide

The prime function of the indicator device is to sink a 4-20mA current input and display the associated

process variable (PV) in appropriate engineering units.

The section below describes the menus accessible on the indicator. By accessing these menus, the user can modify the instrument configuration in many ways. Unless custom selections were specified at the time of order the indicator is set to the factory defaults.

The instrument needs to know at least 2 coordinate pairs to define the relationship between mA input and display PV. The default method is to have scaling (SCAL) set to standard (StND). this allows the user to edit the engineering low (ENLO) and engineering high (ENHI) PV values that correspond to 4mA and 20mA input values, respectively. The default values for the engineering low and engineering high are 0 and 100, respectively, giving a linear display range of 0 to 100 for 4-20mA input.

Alternatively, the user may not know the exact PV values at 4 and 20mA. You can chose auto scaling (AUtO) to solve this problem. This allows the user to edit the engineering low and engineering high PV values that correspond to LO mA and HI mA input values, respectively. When the user accesses the scale low (SCLO) menu entry, the display flashes IPLO (input low) to prompt the user to apply the LO mA value. Once the correct input signal is present and stable, the user should press enter to store. The user is then prompted to apply the HI mA value.

The user can choose linearization type (LIN). None (NONE) is the default, and sets a straight linear relationship between mA input and the PV. The input will go under/over-range at 3.8/21.5mA. Square root (59Rt) root 3/2 (Rt32) and root 5/2 (Rt52) set a $X^{1/2}$, $X^{3/2}$, or $X^{5/2}$ relationship, intended for flow applications where, for example, the flow is proportional to the square root of level. The input

**Burns Connection Head Models #19 & #20
with Loop Powered LED Indicator Instruction Manual**

will go under/over range at 3.8/21.5mA. User-defined linearization using up to 20 coordinate pairs. For example, if the user wanted to apply a 3-segment set of interpolated coordinate points as shown in figure 9, you would select LIN = USER, then set StGS = 3. The user would then set the mA interpolation points as IN1, IN2, IN3, IN4 = 5.1, 6.9, 12.3, 16.95. The corresponding PV interpolation points would be set as OUT1, OUT2, OUT3, OUT4 = 12.6, 32.5, 42.5, 75.1. The input would then go under/over range at 5.1/16.95mA.

Figure 8
User-defined Linearization

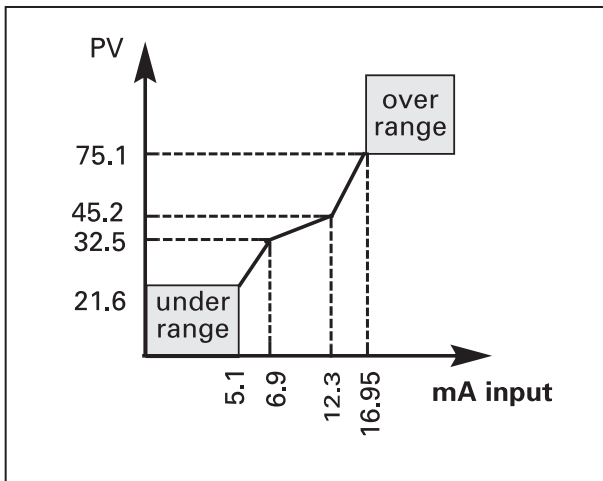

-Menu

When cycling around menu, the title (e.g. LIN, SCAL etc.) is displayed for a second, then the menu entry is displayed ready for editing. See figure 9 below for menu details. Company defaults are shown bold.

Maintenance

Apart from configuration this equipment requires no maintenance. If recalibration is required please contact Burns Engineering for assistance (800-328-3871).

Repair and Warranty Service

Repair and warranty service is available directly from Burns Engineering. Note: Failure analysis is an important part of product improvement. If you have a failure even if out of warranty, please contact us. We will do our best to help you. When returning goods, first call toll free 1-800-328-3871 and obtain an RMA number. Always include a letter of transmittal and the RMA number with the shipment. Providing the following information in the letter will expedite service.

- Type of service and length of time the part has been in service.
- Description of the problem, and circumstances of the failure.
- Name and telephone number of the person who can answer questions about the returned part.
- Complete shipping instructions for return delivery.
- Request for warranty service if appropriate.

For more information please contact us at:

Burns Engineering Inc.
10201 Bren Road East
Minnetonka, Minnesota 55343
1-800-328-3871

Figure 9
Menu Schematic

